

MODEL 564 INSERTED-UNDER-PRESSURE LEVEL OR PRESSURE TRANSMITTER

00-56401

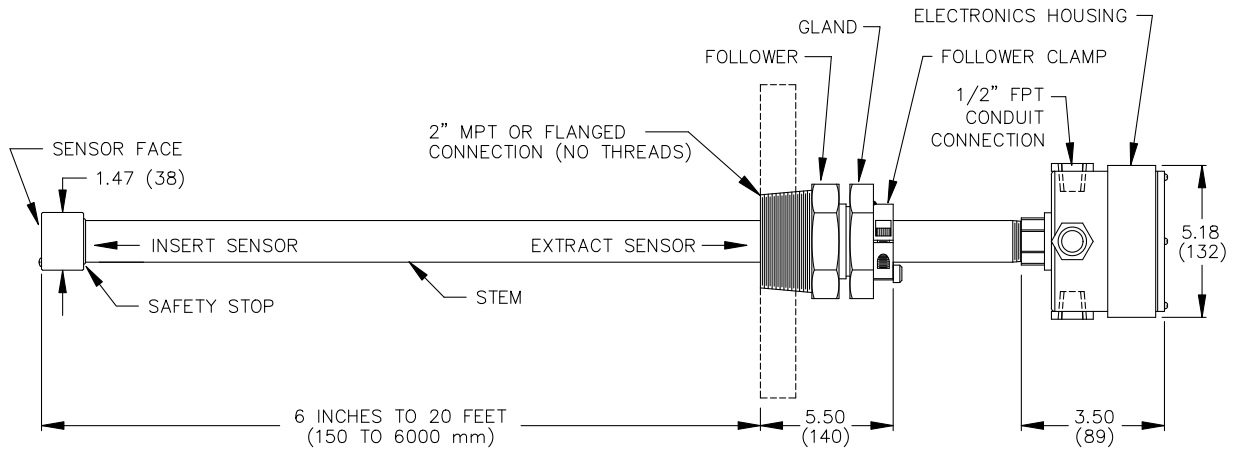

FEATURES

- Intended To Be Inserted Or Removed Without Draining Or Depressurizing The Tank Or Vessel
- Used From Hard Vacuum To 3000 PSIG Pressure
- Suitable For Dirty Liquids And Slurries
- Measures Levels In Tanks Pressurized Up To 15 PSIG (1 Bar) Or Down To Hard Vacuum
- Integral Sealed Electronics Module
- Spark, Voltage Surge, And Noise Protection
- Can Also Transmit The Process Temperature Over A Second 4-20 mADC Signal Loop
- Flush Face Sensing Diaphragm; 316-L Basic

TYPICAL LEVEL APPLICATIONS

Liquid Ammonia Storage Tank Level
Sewage Treatment Digesters
High Reliability Hydrocarbon Confinement
Toxic Materials that must be contained
Paint and Coating Storage Tanks

DESCRIPTION

The Model 564 is a two-wire pressure transmitter designed to measure liquid level and pressure in tanks which cannot be depressurized or allowed to leak. It is suitable for services that are very dirty, leave deposits and generally tend to plug up any cavity or recess they encounter. The ability to insert the sensor face of the Model 564 all the way into the inside of the vessel usually eliminates these problems. Other applications include process materials that tend to set up or crystallize when stagnant; that solidify and plug sensing lines when allowed to cool, slurries of polymerizing agents, and many other difficult to handle materials.

The Model 564 can be inserted from the top or side of a vessel as required. Safety stops prevent accidental ejection of the transmitter and rapid discharge of the tank contents into the environment. The block valve, fittings and adaptors are available from Delta or may be furnished by the user..

SPECIFICATIONS

Technology: Silicon strain gage
Supply Power: 13 to 35 VDC, 2 wire loop powered
Output: 4-20 mADC isolated; Intrinsically Safe
Loop Impedance: 550Ω at 24 VDC; 1100Ω at 35 VDC
Adjustments: Span from 30% to 100% of sensor range. Zero to 30% is basic and to 80% is optional, non-interactive.
Temperature: -20 to +220°F (Process)
 -20 to +180°F (Electronics)
 30 to +130°F (Compensated)
Accuracy: ±0.25% F.S. or better
Thermal Error: ±0.02% F.S./°F maximum
Over Pressure: 2X Range (35 PSI / 2.5 Bar min) without damage; 3X Range (1000 PSI / 70 Bar min) without rupture

OPTIONAL FEATURES

Dampening: Selectable 0.1 to 22 seconds
Indicator: Direct reading LCD display
Temperature Transmitter: 4-20 mA, 2-wire; any 50°F span
High Pressure*: To 3000 PSIG (200 Bar)
 * Not Third Party Approved

LOW PRESSURE INSTALLATION

Most applications are for low pressure (< 25 PSIG) service such as tank head pressure, gas receivers, etc. The Model 564 can be manually inserted (by pushing) or extracted (by pulling) the 564 when the pressure is 25 PSIG (2 Bar) or less. Reasonable care must be taken to prevent damage or injury, even when the pressure is low.

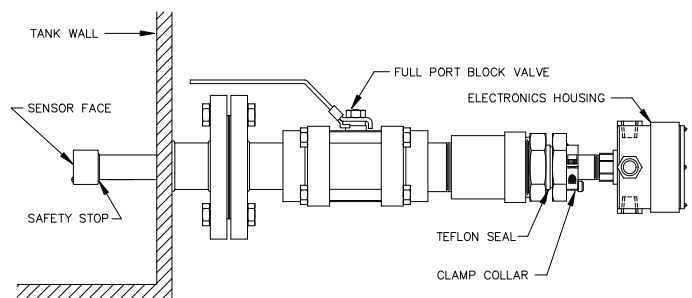

MODEL NUMBERING SYSTEM

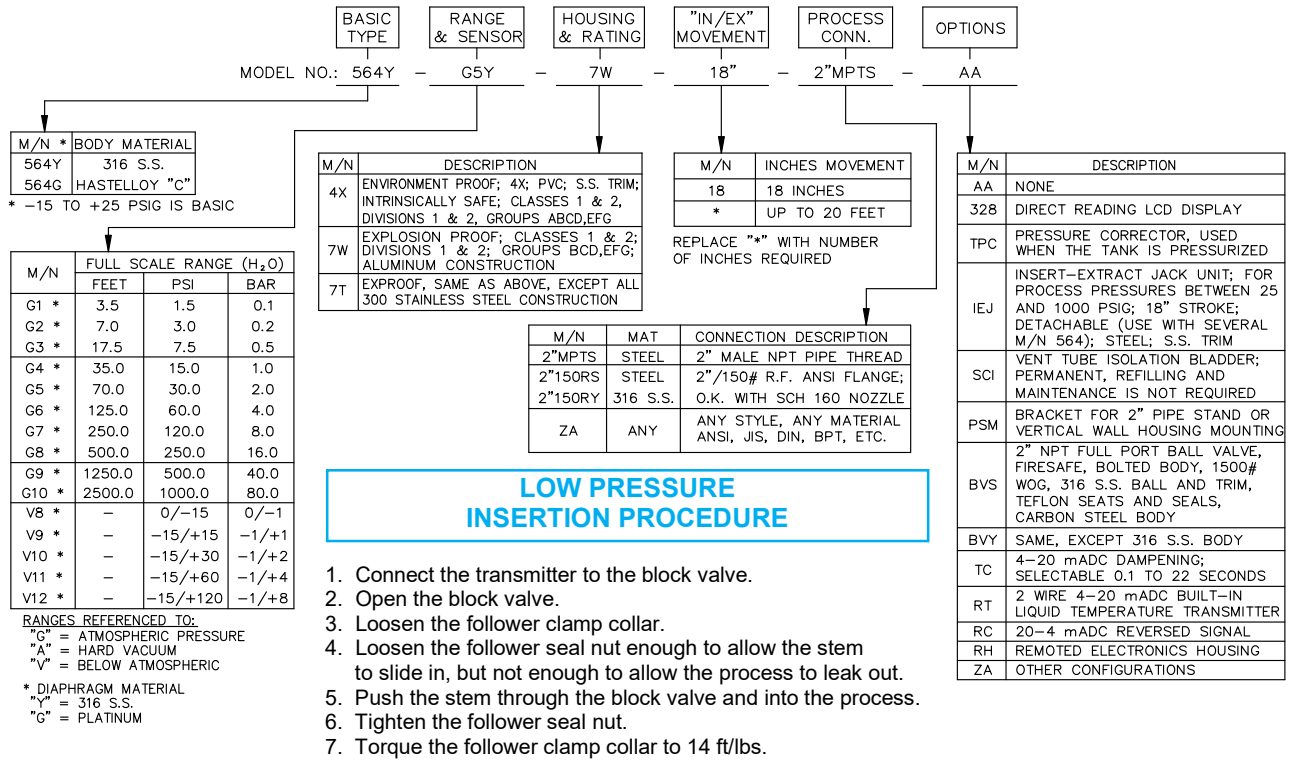

HIGH PRESSURE INSERTION PROCEDURE

Made in the USA by Delta Controls Corp

When the pressure is higher than 25 PSIG, up to 1500 PSIG, then a mechanical jack unit must be used to insert or extract the Model 564. This is a requirement for both safety and ease of operation because the unit can be ejected with a force of 1300 pounds at 1500 PSI (max design pressure).
WARNING - Without the jack, the unit will move out at a high rate of speed when the clamp collar is loosened. It will continue to accelerate until:

- A. It hits someone
- B. It hits equipment in its path
- C. It hits its safety stop

Procedure for inserting the Model 564 with a jack:

1. Connect the transmitter to the block valve
2. If not already done, slide the jacking clamp into position from the side.
3. Bolt the two stay plates in position.
4. Slide the jacking clamp against the pusher bar and tighten to a torque of 14 foot-pounds.
5. Open the block valve and loosen the follower clamp collar.
6. Loosen the follower seal nut. Do not allow the process to leak.
7. Rotate the two insertion screws alternately. Screw one side in about 2" then switch to the other one. Continue until the sensor is in the desired position. Tighten the follower.
8. Tighten the follower clamp collar to a torque of 14 foot-pounds.
9. The jack may be left in place, removed for storage, or used to install another unit.

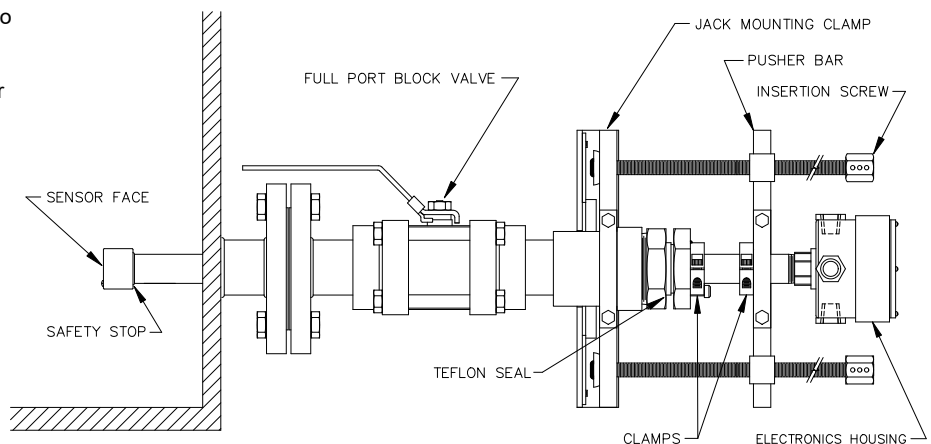

THIRD PARTY APPROVALS

CSA (Canada)
 NRTL/C (USA)
 Intrinsically Safe
 Explosion Proof
 Environment Proof



**Engineered
 Reliability**

585 Fortson Street
 Shreveport, La. 71107 - USA
 P: +1(318) 424-8471
 F: +1(318) 425-2421
 sales@deltacnt.com
 www.deltacnt.com