

MODEL 512/514 CONDUCTANCE PROBE LEVEL SWITCH UP TO 4 CONTROL AND/OR ALARM STATIONS

TS512

FEATURES

- Reliably detects conductive solids or liquids
- Circuit is plastic coated for protection against moisture and corrosion
- DPDT relay is sealed for high reliability
- Unaffected by conductive probe buildup
- Actuation setpoint resistance is adjustable to prevent false switching
- 2 second time delay is basic, 1-60 seconds adjustable is optional
- 4X hoseproof housing is basic
- Low level sensor voltage for safety
- AC signal protects sensing probe life
- Intrinsically safe probe is optional

APPLICATION

The Model 512/514 produces a switching action as a conductive material touches the tip of its sensing probe. An individual probe is required for each switch action point. Each of the switch stations may be wired for alarm action or for differential pump control action. See the electrical wiring diagram for details.

OPERATING PRINCIPLE

The switch station actuates its relay when a small electrical current flows from its sensing probe to the vessel wall or to another probe used for ground return. A 60 Hz low voltage AC signal is applied between the sensing probe and ground. The very small current is conducted between the two when the process liquid touches the sensing probe. This current flow is sensed by an electronics network which actuates the output relay.

On/off differential control is accomplished by using two sensing probes, one of which is longer than the other. The relay is actuated when the liquid level touches the upper probe. The relay actuation disconnects the upper probe and connects the lower probe to the measuring circuit input. The unit is then "latched in" through the lower probe/liquid/ground connection and remains actuated until the liquid level drops below the lower probe. The relay then deactuates, and the upper probe is reconnected to the measuring circuit input.

A single return path is common to all stations. This path can be a probe, metal tank, or earth ground.

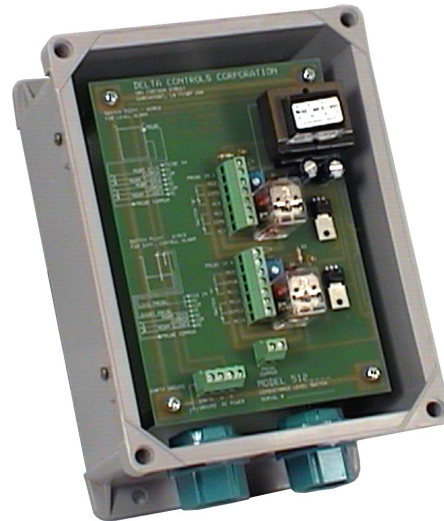

Model 512 with 2 Station Switching and Remoted Housing

Typical Installation of the Model 512/514

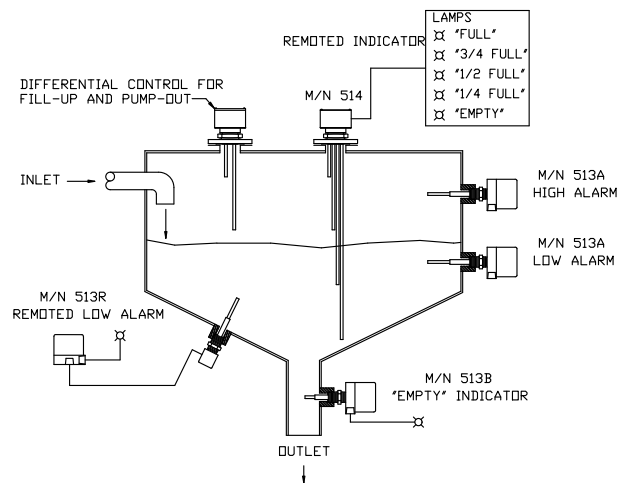

CALIBRATION AND SAFETY

The relay switches when the conductive material makes an electrical connection between the sensing probe and ground or return. The sensing rod(s) length is selected so that the rod tip is at the elevation where switching is required.

The instrument only has a low AC voltage on the sensing probe, even under conditions of an open probe circuit.



Delta Controls
CORPORATION

CONDUCTIVE BUILD-UP APPLICATIONS

The Model 512/514 does a better job on fluids that leave conductive deposits than do most other types of level switches. Many process fluids carry entrained solids, which accumulate on any surface that they contact. These deposits usually remain conductive after the fluid has dropped off of the probe and commonly continue to collect until the physical size of the buildup mass is quite large. The Model 512/514 will continue to operate through a conductive buildup because when the fluid rises and contacts the buildup mass, the sensing current can flow through the conductive buildup, through the fluid, and on to ground return. The sensing probe should enter the vessel vertically from the top. This prevents the collected buildup from bridging across the rod insulation to the tank wall ground, which could cause the Model 512/514 to be continuously activated.

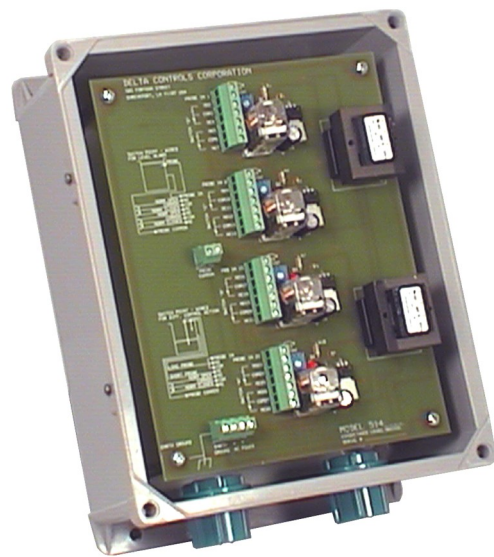

Model 514 with 4 Station Switching and Remoted Housing

SPECIFICATIONS

Relay: 5 amps @ 120 or 240 VAC, 50/60Hz, 4 amps @ 28 VDC; DPDT; (SPDT when wired for differential)
Supply Power: 120 or 240 VAC, 5 VA
Operating Temperature: -20° to +180°F, (PVC housing limit is -30 to 85°C)
Response: 2 seconds fixed time delay (0-60 seconds adjustable optional)
Basic Input: 100 to 35,000 ohms Equiv.
Solution Conductivity: Potable water to strong acids; carbon solids

FLUIDS AND SOLIDS SENSED

This unit will sense the presence of water and almost any water based compound or mixture. A solution having 10% or more free water is usually adequate for operation. Typical examples are: acid, tap water, sodium hydroxide, brines, and mine water.

Most carbons and carboneous solids are conductive and can be detected by the Models 512&514. These solids may be in the form of powders, granules, or lumps. Typical examples are: coal, coke, graphite, and carbon black.

INTERCONNECTION WIRING DIAGRAMS

EACH STATION MAY BE WIRED AS AN ALARM, OR AS AN ON/OFF DIFFERENTIAL CONTROLLER

Model 512 With Two Switching Stations

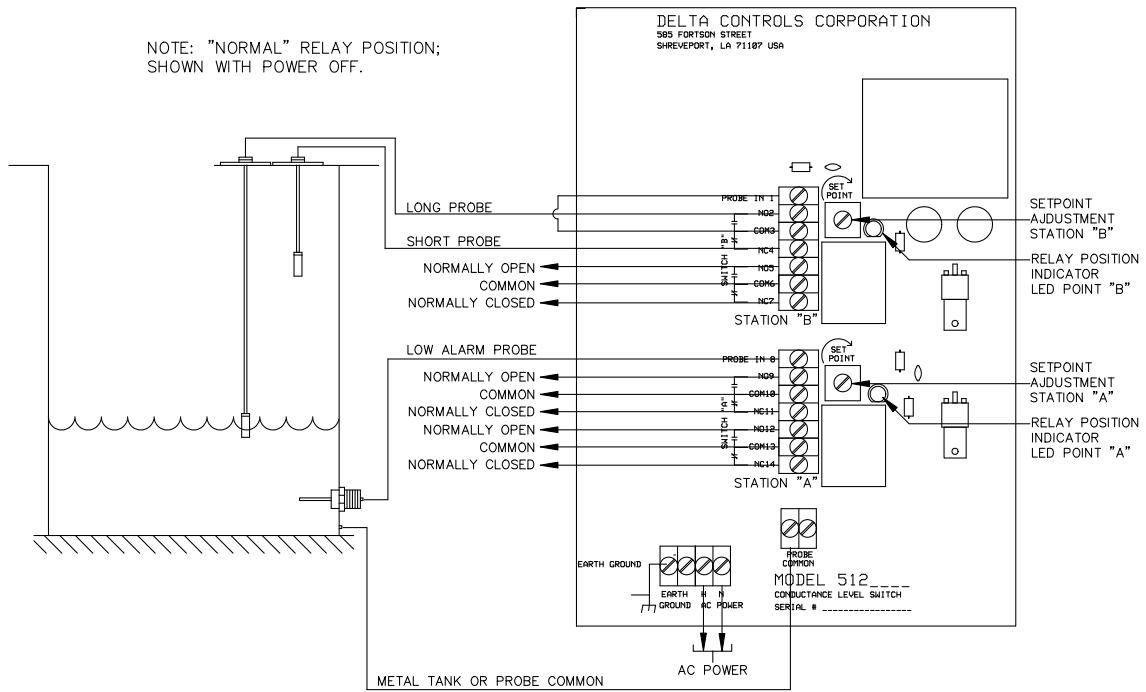

SHOWN: STATION "A" WIRED AS LOW LEVEL POINT ALARM
STATION "B" WIRED AS DIFFERENTIAL LEVEL CONTROLLER

Model 514 With Four Switching Points

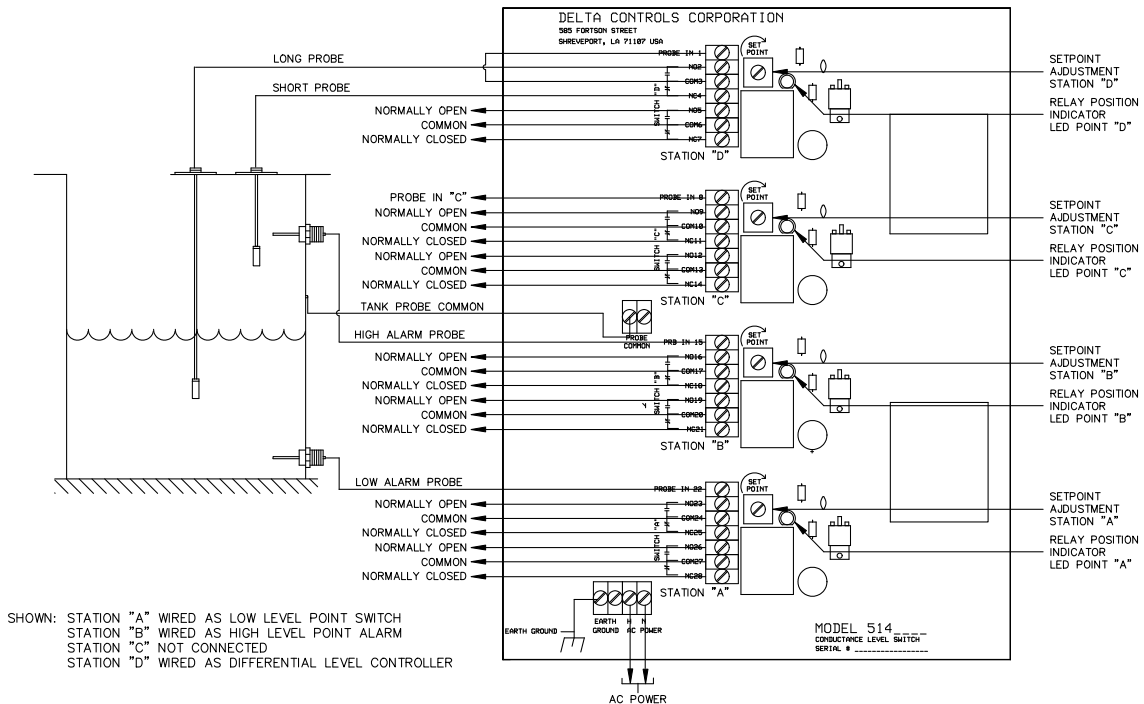

SHOWN: STATION "A" WIRED AS LOW LEVEL POINT SWITCH
STATION "B" WIRED AS HIGH LEVEL POINT ALARM
STATION "C" NOT CONNECTED
STATION "D" WIRED AS DIFFERENTIAL LEVEL CONTROLLER

MODEL NUMBERING SYSTEM

Model P44 Multiple Rod Probes, Remoted Electronics

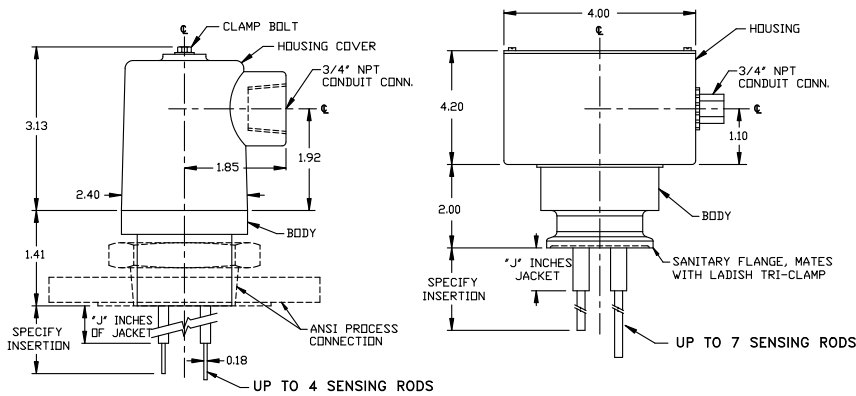

Model P43 Multiple Cable Probe, Integral Electronics Unit

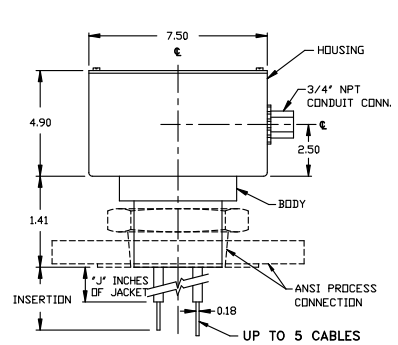

Model P43

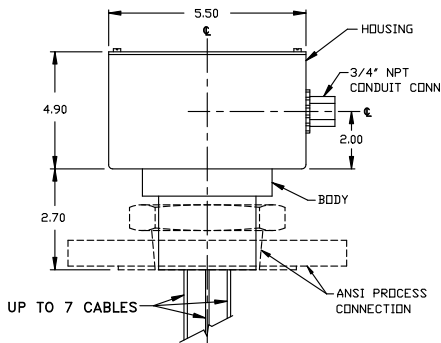

NOTE: CABLE/ELECTRODE ASSEMBLIES ARE SEPARATE ITEMS.

Multiple Cable Probes, Remoted Electronics Units

Model P46

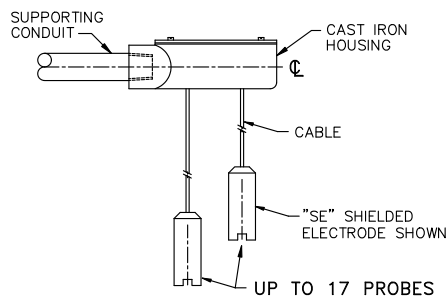

Model P47

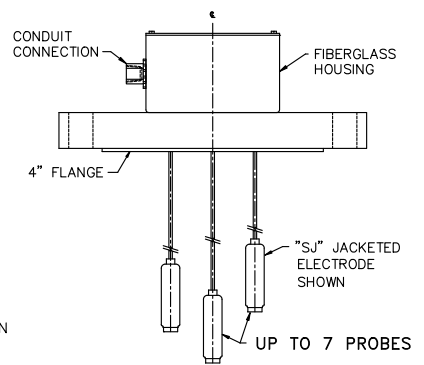

PROBE SPECIFICATIONS

Working Pressure: -15 to 1500 PSIG
Process Temperature: -450 to +1000°F; (-273 to 550°C)
Process Connection: ANSI Flange, Sanitary Flange, NPT, BPT, DIN, Wall bracket, Custom designs

Wetted Materials:

Sensing Rods and Electrodes: 316 S.S., Hastelloy® "C"; Titanium, Monel, etc.

Jackets and Cable Insulation: PVC, PTFE

Housings: PVC, Fiberglass, Aluminum, S.S.

Seals: Viton® "O" rings, PTFE packing

Insertion Lengths (basic):

Rods: 1 inch to 20 feet (25mm to 6M)

Cables: 6 inch to 200 feet

Solution Conductivity:

Potable water to strong acids, Slurries and carboneous solids

Junction Housings:

Type 4X, Hoseproof, for corrosive areas; S.S. hinges, fasteners, and latches

Model "SE" and "SJ" Lower Cable/Electrodes

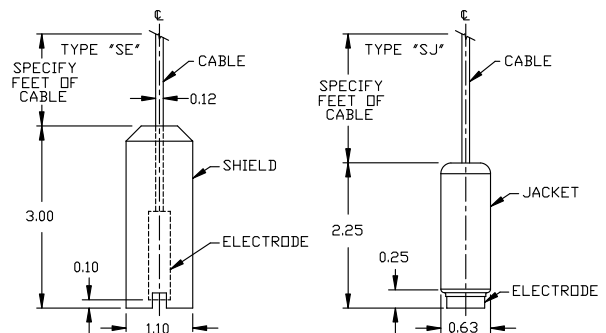

**Engineered
Reliability**

585 Fortson Street
 Shreveport, La. 71107 - USA
 P: +1(318) 424-8471
 F: +1(318) 425-2421
 sales@deltacnt.com
 www.deltacnt.com

MODEL NUMBERING SYSTEM

INTEGRAL
MOUNTING

**BASIC
TYPE**

**SUPPLY
POWER**

**HOUSING
& RATING**

OPTIONS

MODEL EXAMPLE 512C - 1 - 4XI - AA (ORDER PROBE SEPARATELY)

BASIC TYPE	
M/N	NO. RELAYS
512C	2
514D	4

SUPPLY POWER	
M/N	SUPPLY POWER
1	120 VAC,50/60HZ
2	240 VAC,50/60HZ

INTRINSICALLY SAFE PROBE BARRIER;
REQUIRES 36 VAC RATING SUCH AS THE
STAHL MODEL NUMBER 9001/02-412-095-10,
BUY DIRECT; C/F WITH ANY QUESTIONS.

HOUSING & RATING	
M/N	DESCRIPTION & RATING (HOUSINGS THIRD PARTY LISTED)
OF	OPEN FRAME FOR SURFACE MOUNTING BY OTHERS REQUIRES 4 EACH 1/2" SPACERS OR STANDOFFS, ("SO" OPTION)
4XI	HOSEPROOF, S.S. TRIM
7WI	EXPROOF, GROUPS B,C,D,E,F,G; ALSO 4X, ALUMINUM
ZZ	ALL STAINLESS STEEL HOUSING

OPTIONS	
M/N	DESCRIPTION
AA	NONE
TD	0-60 SECOND ADJUSTABLE TIME DELAY
SO	4 EACH MOUNTING STANDOFFS

REMOTE
MOUNTED

**BASIC
TYPE**

**SUPPLY
POWER**

**HOUSING
& RATING**

OPTIONS

MODEL EXAMPLE 512R - 1 - OF - AA (ORDER PROBE SEPARATELY)

BASIC TYPE	
M/N	NO. RELAYS
512R	2
514R	4

SUPPLY POWER	
M/N	SUPPLY POWER
1	120 VAC,50/60HZ
2	240 VAC,50/60HZ

INTRINSICALLY SAFE PROBE BARRIER;
REQUIRES 36 VAC RATING SUCH AS THE
STAHL MODEL NUMBER 9001/02-412-095-10,
BUY DIRECT; C/F WITH ANY QUESTIONS.

HOUSING & RATING	
M/N	DESCRIPTION & RATING (THIRD PARTY LISTED)
OF	OPEN FRAME FOR SURFACE MOUNTING BY OTHERS - MOUNTING REQUIRES 4 EACH SPACERS OR MOUNTING STANDOFFS ("SO" OPTION)
4XR	HOSEPROOF, S.S. TRIM
7WR	EXPROOF, GROUPS B,C,D,E,F,G; ALSO 4X; ALUMINUM
ZZ	ALL STAINLESS STEEL HOUSING

OPTIONS	
M/N	DESCRIPTIONS
AA	NONE
PSM	2" PIPESTAND OR SURFACE MTG BRACKET
SO	4 EACH MOUNTING STANDOFFS FURNISHED
TD	0-60 SECOND ADJUSTABLE TIME DELAY

Model 512 Approx. Weight: 13# Net; 17# Boxed
Model 514 Approx. Weight: 18# Net; 23# Boxed