

MODEL P66 FOR ULTRA CLEAN AND METAL ION FREE APPLICATIONS

NO METAL PARTS, CRACKS OR CREVICES

ALSO USEFUL FOR EXTREMELY CORROSIVE SERVICE

TS P66

ADVANTAGES FOR LIQUIDS AND INTERFACES

- Only virgin Polypropylene or Kynar® plastic is in contact with the process fluid
- Thick plastic jacketing is welded in place
- No cracks, joints, or crevices to collect contaminants
- Suitable for fluids used in silicon chip and electronics manufacturing
- For industrial processes which are extremely corrosive such as hydrofluoric acid plants, pickling lines, and plating solutions
- Plastic surfaces are flame smoothed for the best available surface

APPLICATION

The P66 sensing probe has all plastic wetted parts. It is designed for use in processes and storage tanks where the possibility of contamination cannot be allowed. Some process examples are: injectable solutions, pharmaceutical dilution fluids, heavy water for research, electronic chip making, and high quality plating systems.

The P66 also commonly finds application in industrial process systems, which are extremely corrosive. Kynar® (PVDF) is very inert and unaffected by almost all strong acids and bases below a temperature of 275 °F (135°C). Applications include hydrofluoric acid level, refinery hydroformers, bromine condensers, chlorine generation cells, radioactive processes and wastes.

The P66 is a heavy-duty rugged sensing probe and provides high reliability in demanding applications.

SPECIFICATIONS

Working Pressure: -15 to +300 PSIG (-1 to +21 BAR)

Working Temperature: -40 to +300°F (-40 to +150° C)

Note that W.P. decreases as temperature increases

Insertion Length: Up to 10 feet (3 meters).

Process Connection: 2" / 150 # R.F. ANSI Flange size; other types and sizes are optional.

Wetted Parts: Kynar® (PVDF - Polyvinylidene Fluoride); or Polypropylene

Body and Support Parts: 316 stainless steel; basic

Electronic Modules: Compatible with all models.

Process Temperature Sensing: Optional -125 to 250°F (-85 to 122°C); 4-20 mA signal over a second 2-wire signal loop



OUTLINE DIMENSIONS

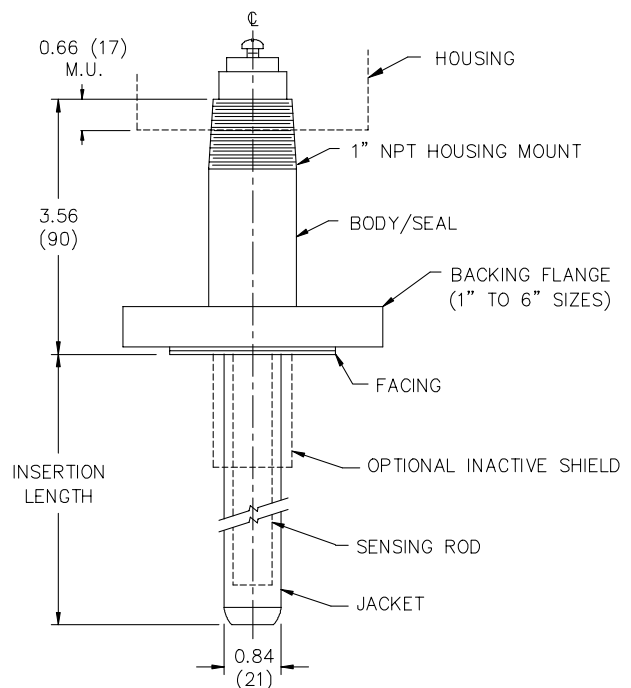

DELTA CONTROLS Corporation

MODEL NUMBERING SYSTEM

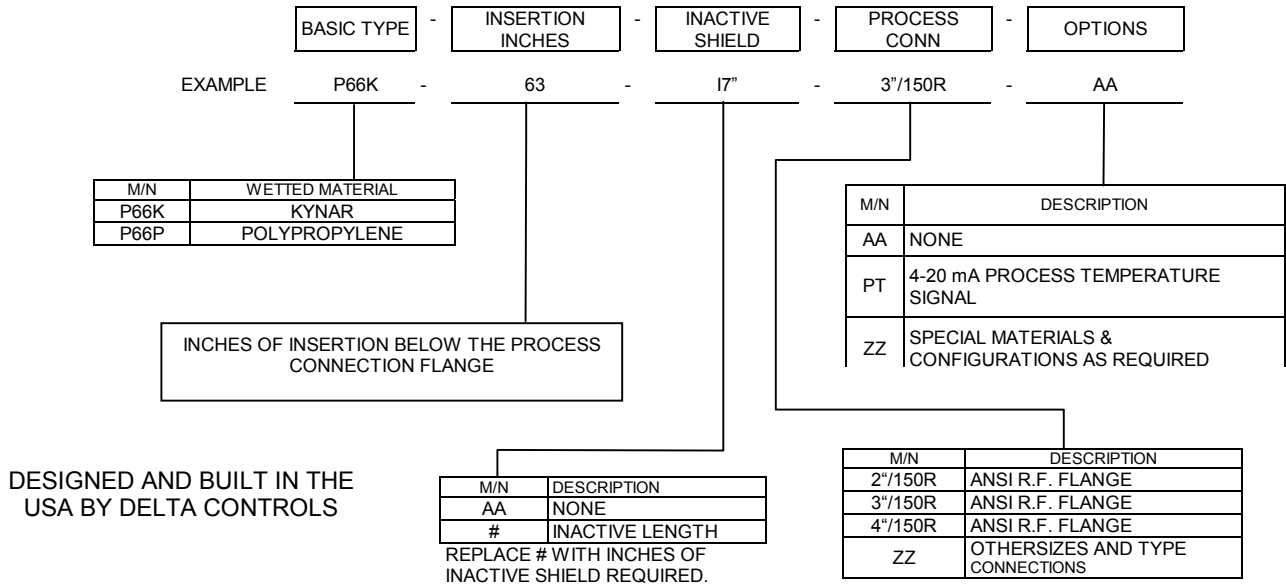

ESTIMATING PROBE PERFORMANCE

STEP # 1 Determine "BSU", which is the total Sensing Unit equivalent when no material is covering the sensing probe.

- (A) BASIC "SU" DUE TO SEAL/BODY/TEMP EXTENSION = 221
 - (B) INCHES SENSING PROBE INSERTION X 3.0 = _____
 - (C) INCHES INACTIVE SHIELD X 22.0 = _____
 - (D) INCHES CABLE FOR REMOTED MODULE X 4.5 = _____
- "BSU" TOTAL = _____

STEP# 2 Determine "ISU", which is the quantity of Sensing Unit change caused by a 1 inch change in the elevation of the process material covering the sensing probe, "ISU" = Read from the graph below

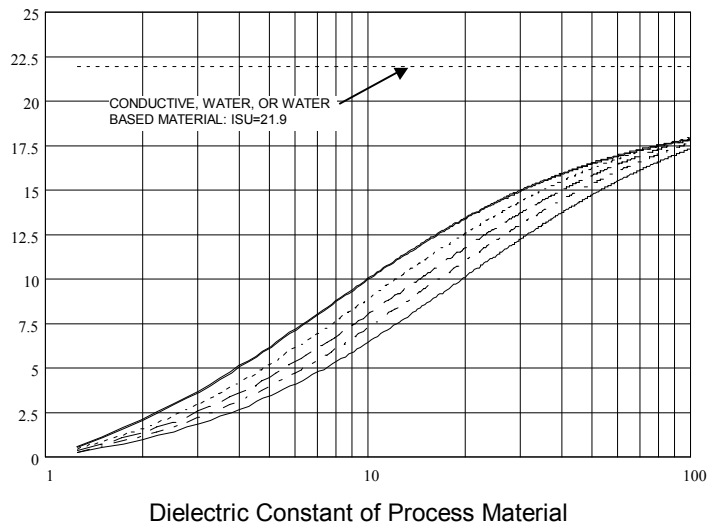
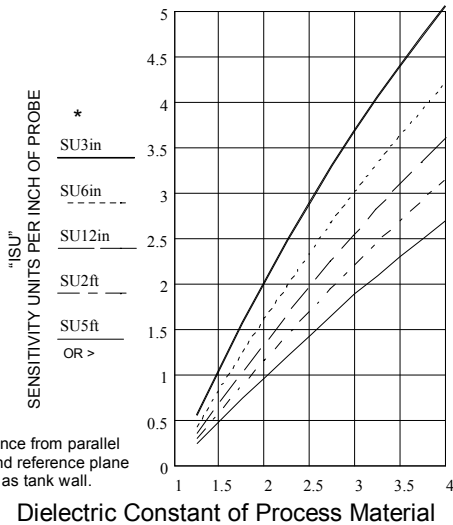

STEP # 3 Insert "BSU" and "ISU" (determined above) into the formulas shown in Application Note # PROB-198, "FORMULAS FOR MODELING AND PERFORMANCE TESTING". Verify that the selected probe and electronics module will meet the needs of the application and provide the expected results.

DELTA CONTROLS Corporation
 585 FORTSON STREET
 SHREVEPORT, LA. 71107 - USA
 PHONE: 318-424-8471 FAX: 318-425-2421

e-mail: delta@deltacnt.com Web Site: <http://www.deltacnt.com>

