

SANITARY PRESSURE/LEVEL TRANSMITTER MODEL 571 COMPACT SIZE

00-57101

FEATURES

- Two Wire Loop Powered 4-20 mADC Transmitter
- Fits Ladish, APC, And Other Sanitary Flanges
- Great For Ultraclean And CIP Service
- Polished Body Is Basic, Polished Housing Optional
- One Piece Electronics / Sensor Module
- Suitable For Tank Level Measurements
- Zero & Span Pots For Field Recalibration
- Spark & Voltage Surge Protection
- Maintenance Free Operation

TYPICAL APPLICATIONS

Ultraclean Water	Fruit Juice
Fermentation Tanks	Vegetable Oil
Milk Processing	Beer, Wine, Spirits
Candy Making	Pharmaceutical Reactors

DESCRIPTION

The Model 571 Level and Pressure Transmitter was designed specifically for food, pharmaceutical and ultraclean applications. The sensor is constructed of 100% 316 S.S. It is completely free from process wetted crevices, cracks, and voids that can harbor contaminants. The back of the sensor assembly is usually vented to atmosphere to compensate for barometric pressure changes.

The electronics are potted in an inner module, located in the stem of the transmitter, which also contains the sensor. The small overall size of this instrument makes it ideal for mounting in confined spaces that would not accommodate standard transmitters.

The Model 571 is commonly used as a liquid level transmitter in vented tanks. The pressure at the bottom of a vented tank containing fluid is linearly proportional to the height and density of the fluid.

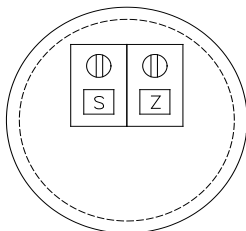

CALIBRATION ADJUSTMENTS
(TOP VIEW SHOWN WITHOUT
HOUSING IN PLACE)



2" SIZE CLAMP FLANGE,
STAINLESS STEEL HOUSING

SPECIFICATIONS

Technology: Silicon strain gage
Supply Power: 13 to 35 VDC 2 wire loop powered
Output Signal: 4-20 mADC isolated, Intrinsically Safe
Loop Impedance: 550 Ω at 24 VDC.
1100 Ω at 35 VDC
Adjustments: Span from 30% to 100% of sensor range. Zero to 30% basic, and to 80% optionally, non-interactive.
Over Pressure: 2X Range (35 PSI min) w/o damage
3X Range (1000 PSI min) w/o rupture
Temperature Range: -20 to +180°F (Continuous)
-40 to +220°F (intermittent)
30 to +130°F (Compensated)
Accuracy: 0.25% F.S. or better
Thermal Error: 0.02% F.S./ F maximum

Made in USA by Delta Controls Corp

MODEL NUMBERING SYSTEM

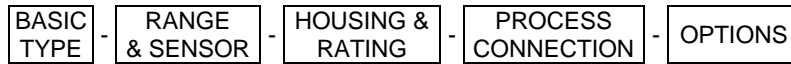

MODEL NO.: 571Y - G4Y - 4XF - 2"TCY - AA

M/N	BODY MATERIAL
571Y	316 S.S.

M/N	DESCRIPTION
AA	NONE

M/N *	FULL SCALE RANGES	
	U.S.A.	METRIC
G1 Y	40" H ₂ O G	0.1 BAR-G
G2 Y	80 " H ₂ O G	0.2 BAR-G
G3 Y	200" H ₂ O G	0.5 BAR-G
G4 Y	15.0 PSIG	1.0 BAR-G
G5 Y	30.0 PSIG	2.0 BAR-G
G6 Y	60.0 PSIG	4.0 BAR-G
G7 Y	120.0 PSIG	8.0 BAR-G
G8 Y	250.0 PSIG	15.0 BAR-G
G9 Y	500.0 PSIG	40.0 BAR-G
A4 Y	15 PSIA	1.0 BAR-A
A5 Y	30 PSIA	2.0 BAR-A
A6 Y	60 PSIA	4.0 BAR-A
A7 Y	120 PSIA	8.0 BAR-A
V8 Y	0/-15 PSIV	0/-1 BAR-V
V9 Y	-15/+15 PSIV	-1/+1 BAR-V
V10 Y	-15/+30 PSIV	-1/+2 BAR-V
V11 Y	-15/+60 PSIV	-1/+4 BAR-V
V12 Y	-15/+120 PSIV	-1/+8 BAR-V

M/N *	LIMITED TO
1" TCY	G4 AND HIGHER
1-1/2" TCY	PSIG RANGES
2" TCY	ALL RANGES

* TUBING SIZE FLANGES; OTHER SIZES AVAILABLE, C/F
 PROCESS CONNECTION MATERIAL: 316 S.S., LADISH "TRI-CLAMP" "TC" SANITARY FLANGE IN BASIC; ACME NUT, APC, CHERRY-BURREL, AND OTHERS ARE AVAILABLE, C/F

M/N	DESCRIPTION (ALL 4X)
4X*	ENVIRONMENT PROOF FLIP-TOP 4X; ALUMINUM CONSTRUCTION WITH WHITE EPOXY OVERLAY; S.S. TRIM; INTRINSICALLY SAFE, CLASSES 1 & 2, DIVISIONS 1 & 2, GROUPS ABCD, EFG
7W*	EXPLOSION PROOF; CLASSES 1 & 2; DIVISIONS 1 & 2; GROUPS BCD, EFG; ALUMINUM CONSTRUCTION
71*	EXPROOF, SAME AS ABOVE EXCEPT ALL 300 S.S. CONSTRUCTION

RANGE REFERENCE TO:

- "G" = ATMOSPHERIC PRESSURE
- "A" = HARD VACUUM
- "V" = BELOW ATMOSPHERE

* REPLACE "*" WITH "F" FOR FLYING LEADS, OR "1" FOR TERMINAL STRIP IN HOUSING

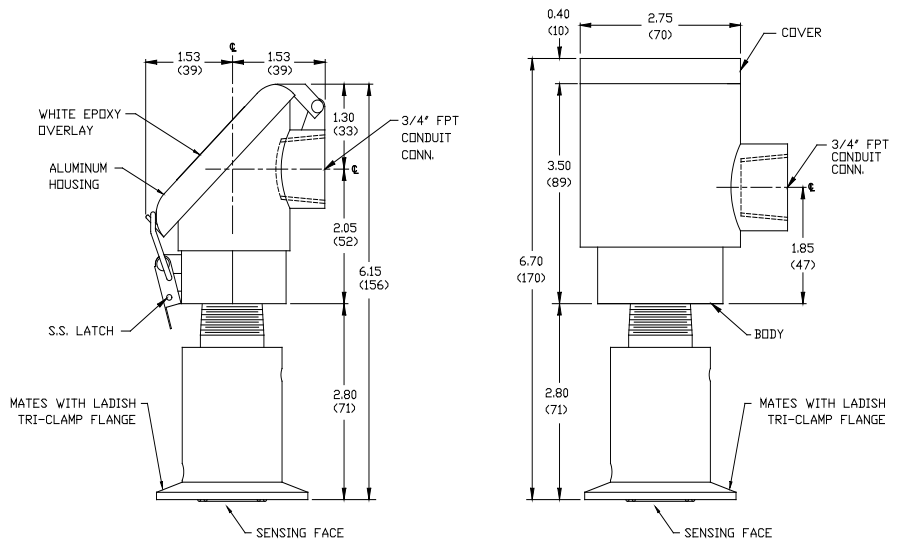

4X HOUSING

EXPROOF HOUSING



DELTA CONTROLS
 CORPORATION

Engineered Sensors - For Difficult Services

585 Fortson Street
 Shreveport, La. 71107 - USA
 Ph: +1(318) 424-8471
 Fax: +1(318) 425-2421
 E-mail: sales@deltacnt.com
 Web: www.deltacnt.com