

MODEL P57 RIGID PROBE WITH PARALLEL GROUND REFERENCE FOR USE IN ALL PLASTIC AND LINED METAL TANKS

ADVANTAGES FOR LIQUIDS OR INTERFACES

- Direct insertion; open construction
- A rod parallel to the sensing probe provides a linear ground reference and increases sensitivity
- PTFE Teflon® sensing rod jacket allows operation in conductive or non-conductive liquids
- High pressure PTFE Teflon® seal is reliable; thousands have been in service for over 30 years
- Service working pressure to 1500 PSIG (100 BAR)
- Service working temperature to 450°F(230°C)
- Can be used to measure liquids with entrained solids in most applications
- Works in highly corrosive applications
- Available with sanitary flange

APPLICATIONS

The P57 probe is commonly used in tanks made of reinforced plastics or metal tanks lined with rubber or plastic. Such tanks do not provide the ground reference plane required by an admittance instrument. The P57 has a ground rod, mounted parallel to the insulated sensing probe, which provides the required ground reference. A stability bar(s) stabilizes the sensing probe and ground rod position when the insertion length is long.

The P57 is widely used on water treating chemicals, stored fuel oil, day tanks, oil/water interface and processed food oils. The open design allows it to be used in many applications; even when solids are entrained in the liquid.

SPECIFICATIONS

Working Pressure: 1500 PSIG (100 BAR) at 100°F (40°C)

Working Temperature: -460 to +450°F (-273 to 233°C); using temperature extensions

Insertion Length: Up to 20 feet (6 meters)

Process Connection: 1 ½" ANSI male pipe thread; larger sizes and flanges are optional

Electronic Module: Compatible with all models

Process Temperature Sensing: Optional

Insulation and Seals: PTFE Teflon®

Wetted Body/Connection Material: Steel, 316 S.S., Hastelloy "C"®, PVC, or Kynar®



OUTLINE DIMENSIONS

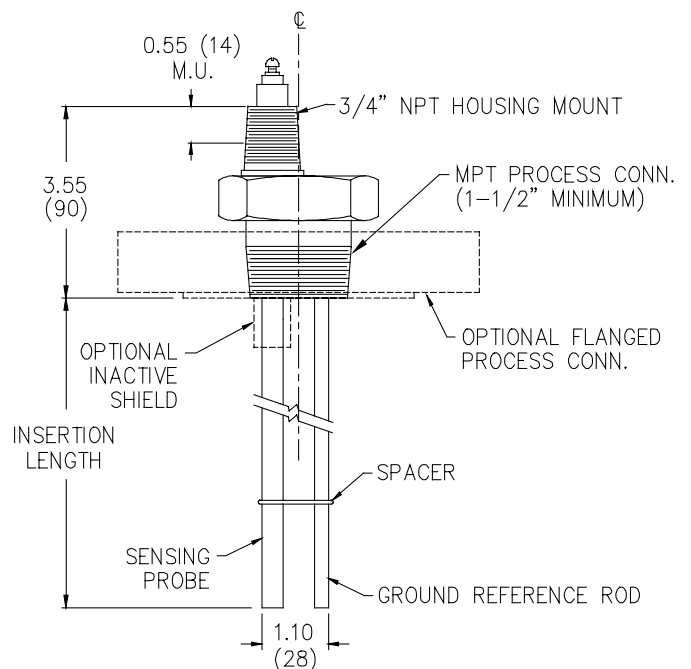

MODEL NUMBERING SYSTEM

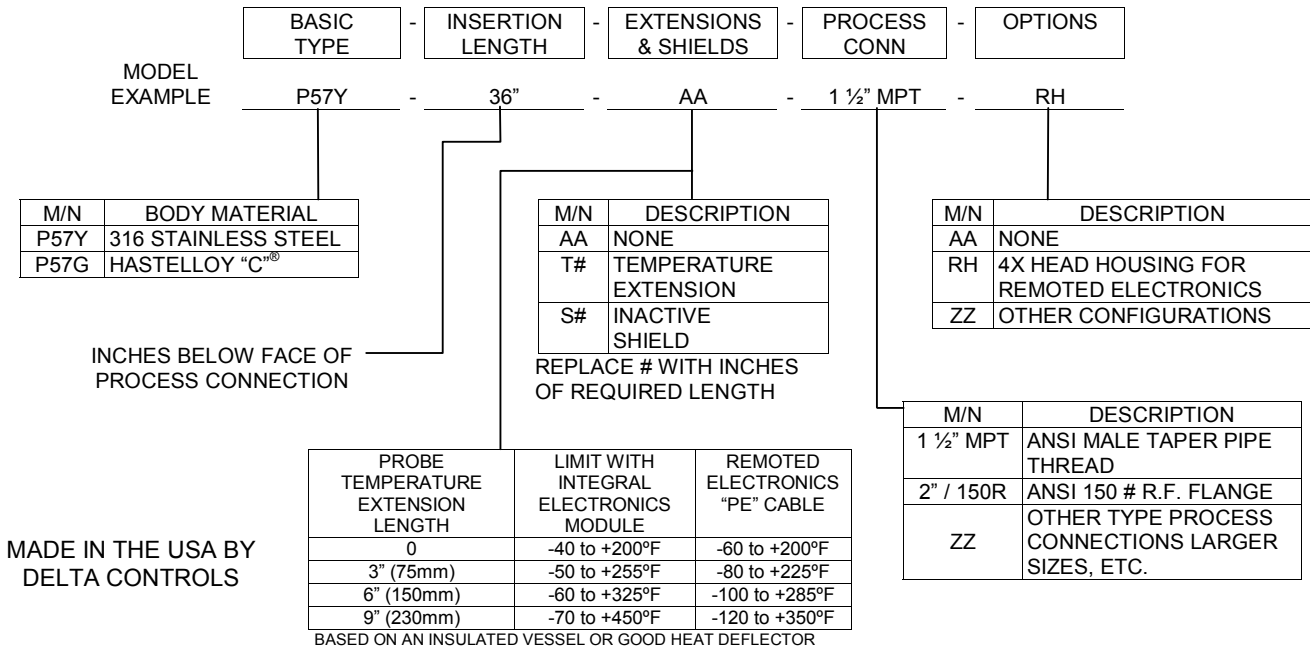

DETERMINING PROBE PERFORMANCE

STEP #1 Determine "BSU", which is the total Sensing Unit equivalent when no material is covering the sensing probe.

- (A) BASIC "SU" DUE TO SEAL / BODY / TEMPERATURE EXTENSION = 116
 - (B) INCHES SENSING PROBE INSERTION X 2.0 = _____
 - (C) INCHES INACTIVE SHIELD X 31.0 = _____
 - (D) INCHES TEMPERATURE EXTENSION X 31.0 = _____
 - (E) INCHES CABLE FOR REMOTED MODULE X 4.5 = _____
- "BSU" TOTAL = _____

STEP #2 Determine "ISU", which is the quantity of Sensing Unit change caused by a 1 inch change in the elevation of the process material covering the sensing probe. "ISU" = Read from the graph below

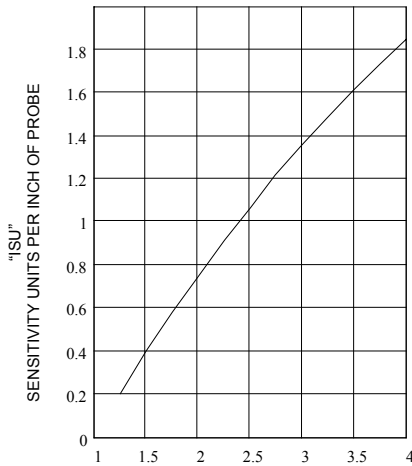

Dielectric Constant of Process Material

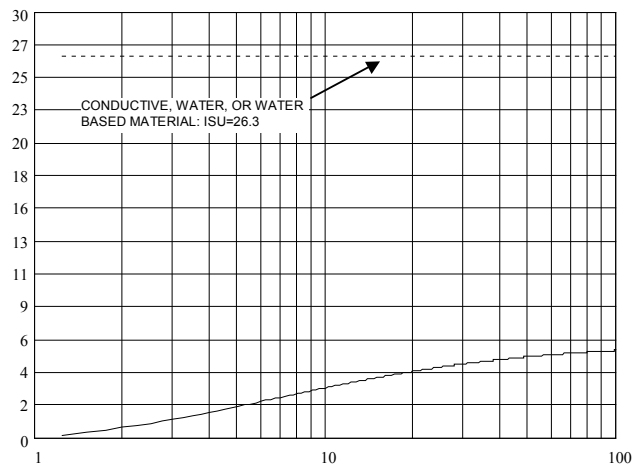

Dielectric Constant of Process Material

STEP #3 Insert "BSU" and "ISU" (determined above) into the formulas shown in Application Note # PROB-198; "FORMULAS FOR MODELING AND PERFORMANCE TESTING". Verify that the selected probe and electronics module will meet the needs of the application and provide the expected results.

DELTA CONTROLS Corporation

585 FORTSON STREET
SHREVEPORT, LA. 71107 - USA
PHONE: 318-424-8471 FAX: 318-425-2421

e-mail: delta@deltacnt.com Web Site: <http://www.deltacnt.com>

