

MODEL P22 AND P23 HIGH GAIN, WITH HEAVY TUBULAR GROUND

ADVANTAGES FOR LIQUIDS & INTERFACES

- High inherent gain sensitivity
- Allows full scale calibration over a very small level change
- Works on viscous liquids or those carrying entrained solids
- Works on liquids with low Dielectric Constant
- Insensitive to surface turbulence and splashing
- Built in ground reference works on lined tanks or all plastic tanks
- Produces a linear output signal in an irregular tank
- Allows calibration outside the vessel
- Strong, resists flowing currents, waves, vortices

APPLICATION

This probe is equipped with a wrap around tubular ground reference sheath. It has high inherent gain sensitivity and allows full scale calibration over just a few inches when the liquid is conductive. The ground sheath is large and provides an open bore. It is intended for use when the liquid is viscous or carries entrained solids. The open bore also allows fast speed of response and resists plugging. The tubular ground reference produces a linear output signal when in a horizontal cylinder or other tank with non-linear sidewalls. The electronic module/probe combo can be calibrated outside the vessel, when required, for convenience or safety.

The P23 probe is for interface service, and is exactly the same as the P22, except that it has vertical slots milled into the tubular ground reference sheath. These slots are offset and overlapping so that the liquid is always free to flow in or out of the sheath. This is a necessity when being used for interface service. The interface transition zone must not be kept from the sensing probe by a solid tube wall.

SPECIFICATIONS

Process Working pressure 1500 PSIG (100 BAR) at 100 °F (38°C)

Process Temperature: -460 to +450 °F (-273 to +230 °C).

Materials: 316 SS and PTFE Teflon® are basic; other metals are optional.

Process Connections: 2" MPT is minimum; any larger threaded or flanged connection is optional.

Ground Sheath: Metal tube, welded to the gland body.

Sensing probe centering guides are provided as needed.

Slotted Ground Sheath: Standard on Model P23.

Electronic Module: Compatible with all models.

Maximum Insertion: 20 feet (6 meters).

Bottom Support Bracket: May be required when insertion is over 60 inches and the liquid is turbulent.

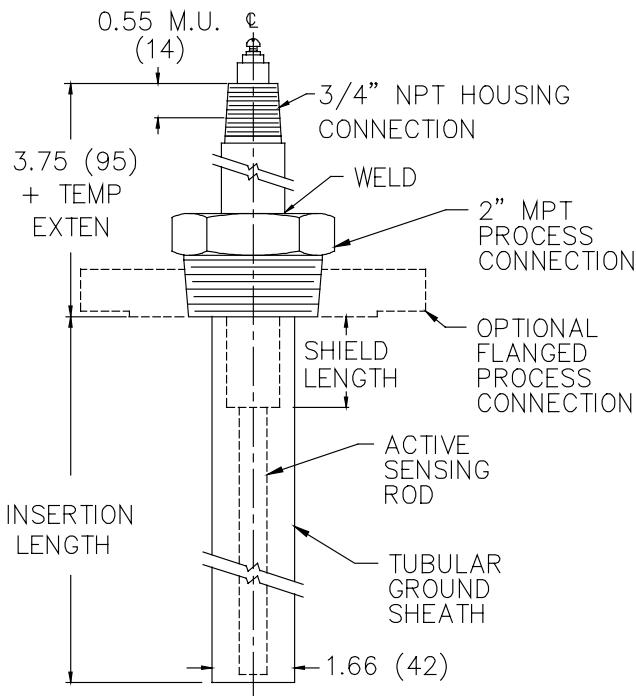
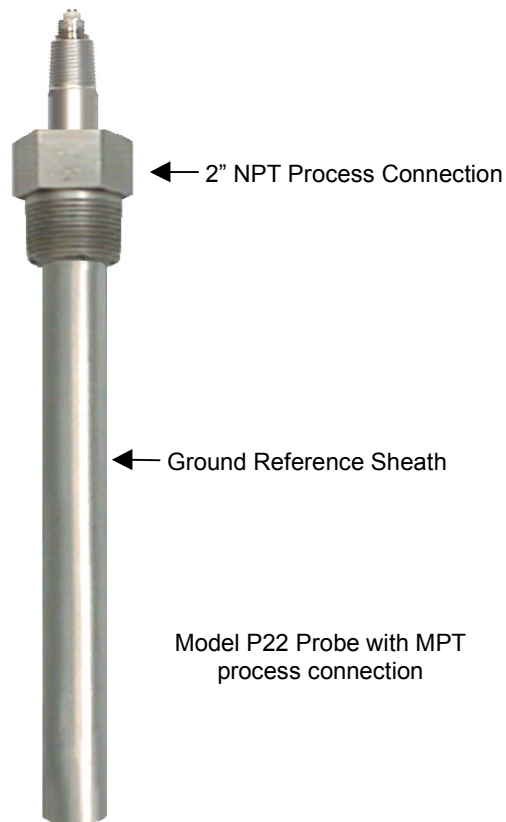

MODEL NUMBERING SYSTEM

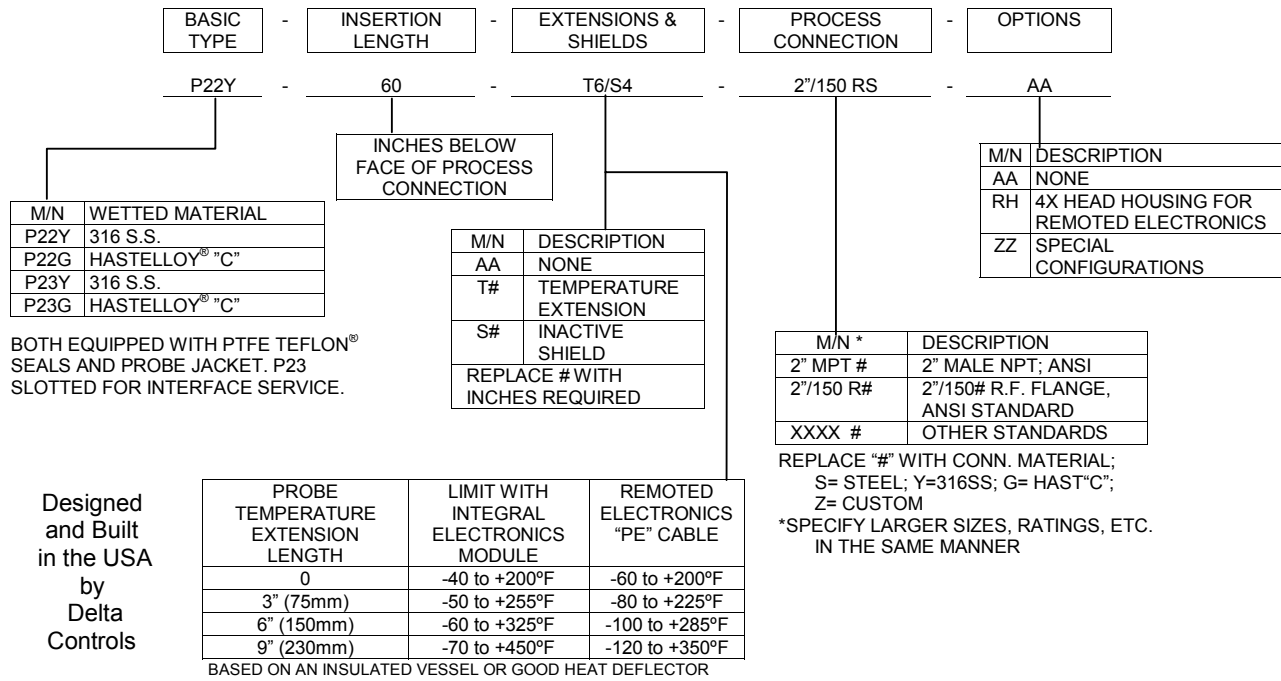

ESTIMATING PROBE PERFORMANCE

STEP # 1 Determine "BSU", which is the total Sensing Unit equivalent when no material is covering the sensing probe.

- | | |
|---|----------------|
| (A) BASIC "SU" DUE TO SEAL/BODY | = 137.0 |
| (B) INCHES SENSING PROBE INSERTION X 3.7 | = _____ |
| (C) INCHES INACTIVE SHIELD X 31 | = _____ |
| (D) INCHES TEMPERATURE EXTENSION X 31 | = _____ |
| (E) INCHES CABLE FOR REMOTED MODULE X 4.5 | = _____ |
| "BSU" TOTAL | = _____ |

STEP# 2 Determine "ISU", which is the quantity of Sensing Unit change caused by a 1 inch change in the elevation of the process material covering the sensing probe, "ISU" = Read from the graph below

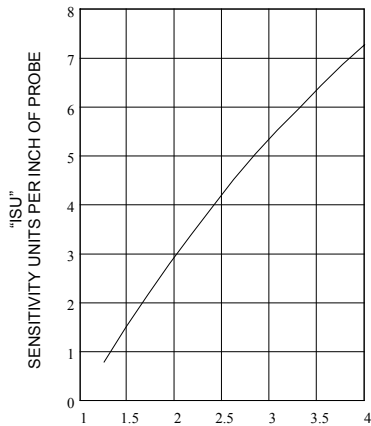

Dielectric Constant of Process Material

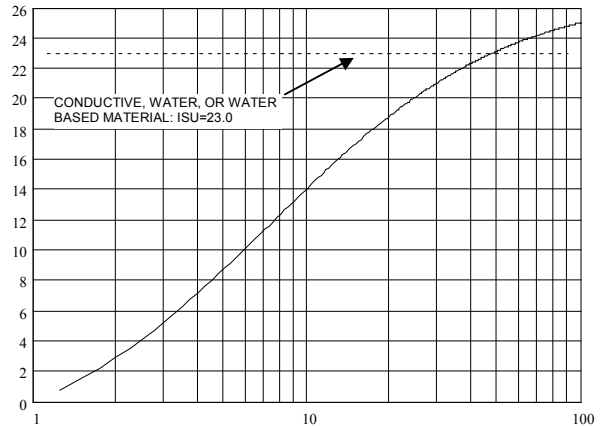

Dielectric Constant of Process Material

STEP # 3 INSERT "BSU" AND "ISU" (DETERMINED ABOVE) INTO THE FORMULAS SHOWN IN APPLICATION NOTE # PROB-198; "FORMULAS FOR MODELING AND PERFORMANCE TESTING". VERIFY THAT THE SELECTED PROBE AND ELECTRONICS MODULE WILL MEET THE REQUIREMENTS OF THE APPLICATION AND PROVIDE THE EXPECTED RESULTS.

DELTA CONTROLS Corporation

585 FORTSON STREET
 SHREVEPORT, LA. 71107 - USA
 PHONE: 318-424-8471 FAX: 318-425-2421

e-mail: delta@deltacnt.com Web Site: <http://www.deltacnt.com>

