

# TYPE 627 INLINE OPEN BORE MECHANICAL FLOW SWITCH

## -- DETECT 1.2 GPM (4.5 LPM) FLOW, NO PRESSURE LOSS --

TS 627

### APPLICATION

The Model 627 is a target actuated flow switch and is equipped with a body that fits into and becomes part of the pipeline. It is similar to the Model 624.

The Model 627 is equipped with a "fitted" target that nearly fills the inside area of the in-line pipeline body at low to "no" flow rates. The target is the "full swing" type and swings back 90° to rest against the inside of the pipeline when the flow rate equals the minimum calibrated flow rate.

The target has been "cupped" and "fitted" so that it is flush against the interior curve of the pipeline during higher flow rates. Only the thin edge of the target plus its support block contacts the flow. The inside area of the pipeline is not restricted and the result is a fully open bore. This design produces a negligible pressure drop while allowing an extremely high velocity throughput. Even so, the 627 can actuate at a very low pre-calibrated flow rate.

The 627 is useful for a wide variety of applications, including exothermic reactor cooling water; blending systems to verify that an ingredient has, in fact, been added; fire water systems; tank car complete drainage; and product transfer completion tasks.

### OPERATING PRINCIPLE

Connection of the target to the output switch is done magnetically. A heavy-duty solid sealing tube separates the process fluid from the switch mechanism. Failures due to seal, diaphragm, and bellows leaks are eliminated.

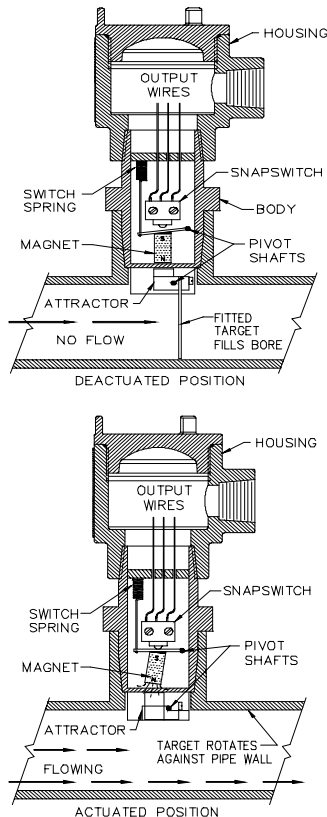

3"/150# RF ALLOY 20 BODY

### HARDWARE MODEL NUMBER\*

\*Application and Service Number must also be provided.

Actuation Point: Within 10% of that specified  
 Housing: Class 1, Division 1, Groups BCD, X-Proof, also 4X, IP67.  
 Third Party Listed by CSA NRTL/C (USA & Canada)  
 Body/Tube Conn: NPT; flanged ANSI, METRIC

Basic Type	Wetted Material	Switch Contact	Pipeline O.D./I.D.	Pipeline Conn.	Options
------------	-----------------	----------------	--------------------	----------------	---------

Example 627 - BBB - C - 3.50/3.07 - 3"/150/RF - AA

#### WETTED MATERIAL COMBINATIONS BY SIZE

M/N	Flanged or Welded Size	Body	Trim	Target
SCY	2" to 8"	Steel	400 SS	316 SS
SYU	2" to 8"	Steel	316 SS	316 SS
BYU	2" to 8"	304 SS	316 SS	316 SS
YUU	2" to 8"	316 SS	316 SS	316 SS
MMU	2" to 8"	Monel	Monel	Monel
GGU	2" to 4"	Hast. C	Hast. C	Hast. C
CGU	2" to 8"	CPVC	Hast. C	Hast. C

Titanium, Alloy 20, and other material are available

M/N	CONTACT	AMPS *	MAX HF
A	SPDT	10	220
B	SPDT	5	450
C	DPDT	10	220
H	DPDT	5	450

\* Ratings up to 250 VAC;  
 all rated 4 amps at 24 VDC

M/N	DESCRIPTION
AA	None
FJ	Body/Tube Flange
SH	304 SS Housing
TS	Wiring Terminals
TC	Traceable Calibration

BUTT WELD ENDS	
SIZE	SCHEDULE
1½" to 8"	10 thru 160
2000 PSIG MAX W.P.; UP TO 5000 PSIG OPTIONAL	

FLANGED CONNECTION		
SIZE	RATING	FACE
2" to 8"	150# to 1500#	RF, FF, RTJ

Example: M/N for:  
 2" S40 = 2.37/2.06  
 4" S80 = 4.50/3.83

**SWITCH POINT IS PRE-CALIBRATED TO RELIABLY DETECT A SPECIFIED FLOW RATE**

Media	Switch Action at Flow Rate	BODY SIZE (Based to ANSI Schedule 40 Pipe)					
		2	2 1/2	3	4	6	8
Water at 77°F	Actuate – GPM	2.2	3.1	4.8	8.5	15	20
	Deactuate – GPM	1.2	1.7	2.6	4.7	8.3	11
Air at STP*	Actuate – SCFM	11	13	15	20	42	70
	Deactuate – SCFM	6.1	7.2	8.3	11	23	39

\* STP is 77 °F and 1 Atm (25°C AND 1 BAR)      GPM X 3.785 = LPM,    CFM X 0.028 = M3/M

**FACTORS FOR LIQUIDS OR GASES WITH DENSITIES DIFFERENT FROM WATER OR AIR AT STP**

SPG (Density)	0.50	0.55	0.60	0.65	0.70	0.75	0.80	0.85	0.90	0.95	1.05	1.10	1.15	1.20	1.25	1.30	1.35	1.40	1.45	1.50
Multiply by	1.41	1.35	1.29	1.24	1.19	1.15	1.12	1.08	1.05	1.02	0.97	0.95	0.93	0.91	0.90	0.88	0.86	0.84	0.82	0.80

**Complete information is required to calibrate the switch point.  
Provide the service details by building up an application number as shown below:**

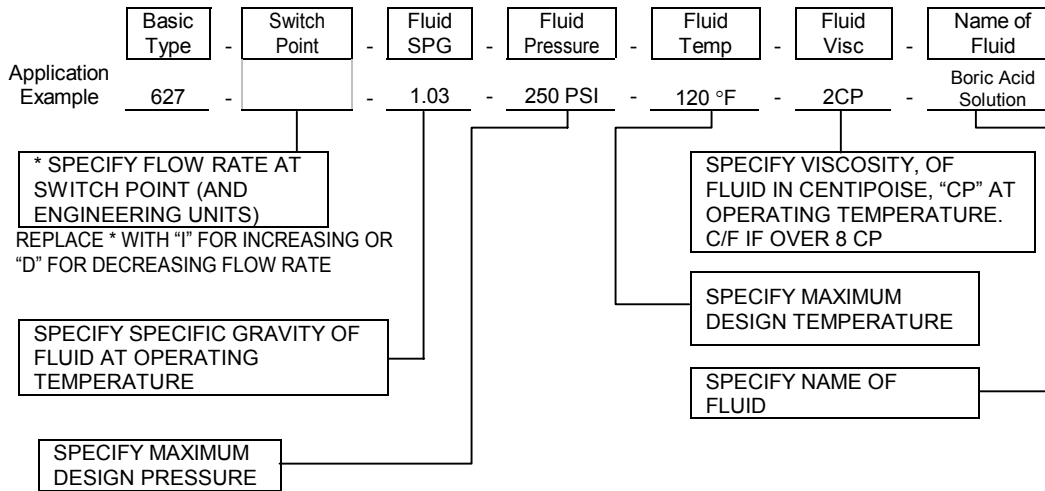

**OUTLINE DIMENSIONS**

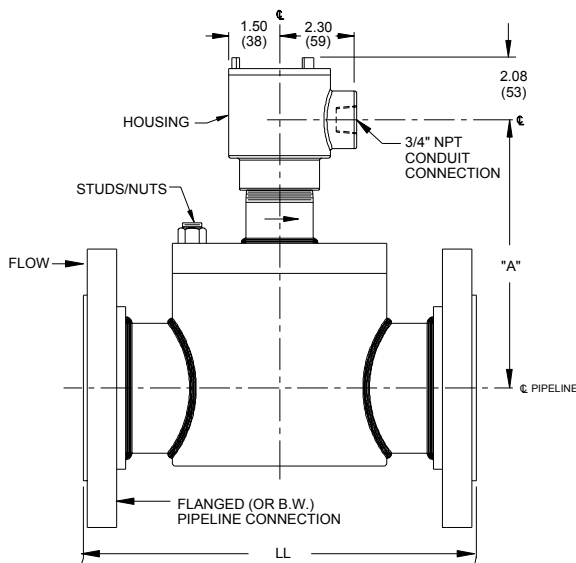

PIPELINE (ANSI SHOWN)*		PIPELINE CONNECTION			
SIZE	DIM	150# RF		BUTTWELD	
		INCH	MM	INCH	MM
2"	"LL"	10.0	254	9.6	244
	"A"	6.0	152	6.0	152
3"	"LL"	12.0	305	11.6	245
	"A"	7.6	193	7.6	193
4"	"LL"	14.0	356	13.6	345
	"A"	8.8	224	8.8	224
6"	"LL"	17.0	432	16.6	422
	"A"	8.4	213	8.4	213

\* METRIC PIPE AND OTHER SIZES ARE OPTIONAL

**DELTA CONTROLS CORP**  
Engineered Sensors – For Difficult Services  
585 Fortson Street. 71107 - USA



Voice: 318-424-8471  
Fax: 318-425-2421  
E-mail: delta@deltacnt.com  
Web Site: http://www.deltacnt.com