

# TYPE 625 ULTRA LOW FLOW SWITCH DEACTUATION ADJUSTABLE 0.03 TO 0.8 GPM (0.23 TO 3.0 LPM) LIQUID 0.15 TO 2.0 SCFM (4.2 TO 18.4 CDM)

TS 625

## APPLICATION

The Type 625 produces on/off switching action at a preset rate of flow. It is used for flow protection, safety monitoring, purging for explosion proofing, etc.

## OPERATING PRINCIPLE

The flowing fluid may pass through both the variable piston annulus and/or the bypass valve. A pressure drop is created across the piston due to the flow rate of the fluid. Increasing differential pressure causes the piston to move and compress the range spring. When the piston magnet is carried far enough, the switch magnet is attracted and the output snap switch is actuated. The amount of bypass valve opening determines the flow rate switching point.

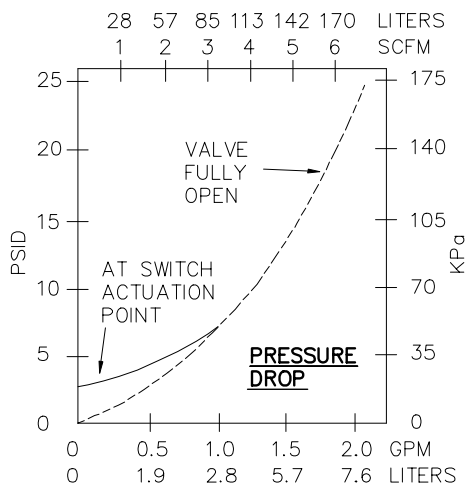
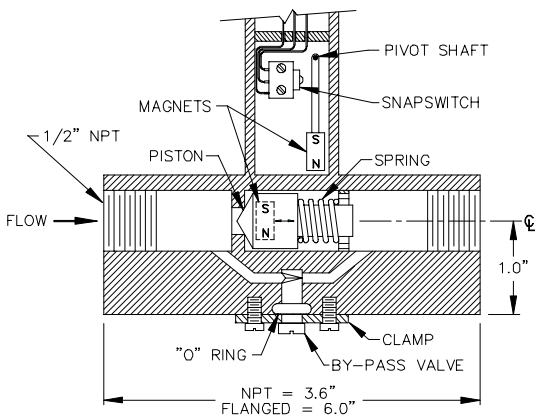

Pressure Drop at Various Flow Rates



Flanged Body



1/2" NPT  
Barstock Body

## MODEL NUMBERING SYSTEM

**Actuation Point:** Within 5% of the set flow rate  
**Housing:** Class 1, Division 1, Groups BCD, X-Proof, also 4X, IP67,  
 Third Party Listed by CSA NRTL/C (USA & Canada)  
**Body/Tube Connection:** NPT; flanged optional

Basic Type	Wetted Material	Switch Contact	Body Size	Options
------------	-----------------	----------------	-----------	---------

Example 625 - YYD - B - 1/2" FPT - AA

M/N	BODY	TRIM	"O" RING
LBZ	Brass	314 SS	Nitrile
YYD	316 SS	316 SS	Teflon

Note: Teflon "O" Ring if over 220°F

M/N	DESCRIPTION
AA	None
ZZ	Other Housings and Materials

M/N	CONTACT	AMPS *	MAX TEMP	
			°F	°C
A	SPDT	10	220	105
B	SPDT	5	300	150
C	DPDT	10	220	105
H	DPDT	5	300	150

\* Ratings up to 250 VAC;  
 all rated 4 amps at 24 VDC

M/N	MATERIALS
1/2" FPT	Brass or 316 SS
1" 150# RF	316 SS only
1" 300# RF	316 SS only
1" 600# RF	316 SS only

1100 PSIG IS MAX WKG  
 PRESSURE, LIMITED BY  
 FLANGE

**DELTA CONTROLS CORP**  
 Engineered Sensors – For Difficult Services

585 Fortson Street Shreveport, La. 71107  
 Voice: (318) 424-8471 Fax: (318) 425-2421  
 Email: [delta@deltacnt.com](mailto:delta@deltacnt.com) Website: [www.deltacnt.com](http://www.deltacnt.com)