

MODEL 103, 105 PROBE TYPE LEVEL SWITCHES

Works on Liquids, Solids, and Interfaces

TS103

- R.F. Admittance measuring circuitry
- Insensitive to process coatings and buildup
- Choice of integral or remote electronics housing
- Design is accurate, simple, and very reliable
- Ambient temperature range -40°F to $+185^{\circ}\text{F}$ (-40°C to 85°C)
- Corrosion resistant, NACE #MR-01-75 optional
- Heavy duty sealed relay contacts
- High or Low relay failsafe action
- Adjustable 1-60 second time delay
- High reliability; 100 hour operational quality testing
- Epoxy sealed electronics module survives harsh environments and area vibration
- Process pressures up to 10,000 psig (700 bar)
- Process temperatures from -400°F to 750°F (-273°C to 400°C)
- Choose from application specific probe shapes, styles, configurations, and process connections
- Wide choice of wetted materials includes Steel, Stainless, Teflon®, Kynar®, Monel, and Ceramics
- Threaded, flanged, or bracket mounting
- Sealed relay for corrosive conditions

APPLICATION

The Model 103, 105 probe type switches use RF Admittance technology to produce switching action when a material level crosses the setpoint of its sensing probe. Many probe configurations are available; the proper style is determined by the service.

The interface position between two liquids with different dielectric constants can be accurately detected by the switches. The units will even average out a cloudy interface and produce a precise switching action as its position passes the set point. A limitation is that one of the liquids must be nonconductive. They are not sensitive to SPG (specific gravity) variations.

OPERATION

The Model 103, 105 utilizes admittance technology to measure how much of its sensing probe is covered by the liquid. This is accomplished by generating a radio frequency pulse of energy which travels from the sensing probe to the ground reference (usually the tank wall). The amount of liquid between the two determines how much energy is transferred. The amount of energy flowing (very small and low level in all cases) is a highly repeatable measure of the liquid level or interface position. The amount is compared to an internal reference and produces a switching action at a selected material elevation.

DESIGNED AND BUILT IN THE USA BY DELTA CONTROLS



Model 103 in Explosion Proof Housing

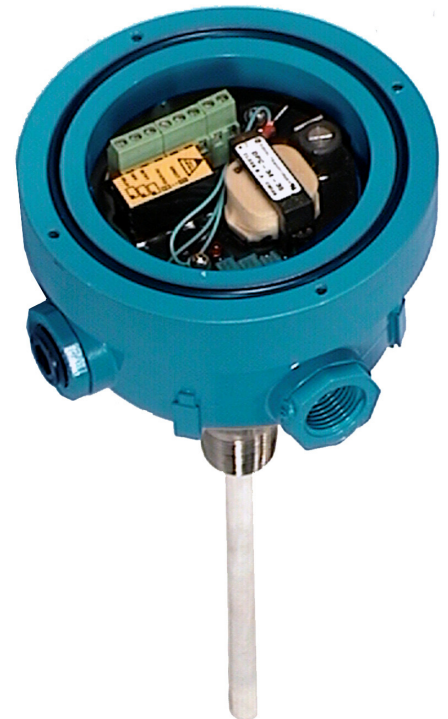

Model 105 in Hoseproof Housing with cover removed

DELTA CONTROLS Corporation

PROBE AND DIELECTRIC CONSTANT

Integral mounting produces a simple one-piece unit, which generally results in the lowest installed cost. Alternately, the Model 105 electronics module may be located 50 feet away from the probe. A coaxial cable connects the remoted electronics to the sensing probe.

The probe may be mounted in any position; vertical, horizontal, or at an angle. Horizontal mounting is usually preferred for alarm action because it provides the sharpest switch point definition. The Model 105, with adjustable differential action (where the OFF setpoint is different from the ON setpoint) requires that the probe be mounted either vertically or at an angle. The material level must move past the two points on the probe where switch action is to occur.

BASIC SPECIFICATIONS

- **Level range:** Switching at any point along the length of the probe selected. Maximum range ("DSU") 4000 Sensing Units
- **Differential:**
Model 103 Fixed 2 SU for alarm service
Model 105 Fully adjustable over balance of range
- **Relay Contacts:** Sealed for corrosive conditions.
Model 103 10A @ 250 VAC SPDT
Model 105 5A @ 250 VAC DPDT
- **Time Delay:** 0.25 to 60 seconds adjustable
- **Operating Temperature:** -40°F to +185°F (-40°C to +85°C)
- **Temperature Effect** ±1 SU; typically less than 1/10" in water; 0-150°F (-18°C to 65 °C)
- **Probe Sensing Circuit:** Intrinsically safe on the Model 105, explosionproof on the Model 103
- **Electronics Module:** Potted for high reliability.
- **Housing:** Third Party Listed by: CSA (Canada) NRTL/C (USA)

OPERATION

Select action:

Direct Action: Relay is deactuated when the material is below the setpoint.

Reverse Action: Relay is deactuated when the material is above the setpoint.

Alarm: Horizontal probe position: The material is allowed to cover the probe rod. The setpoint pot is then turned until the relay operates. Calibration is complete.

Adjustable Differential: (Model 105); Vertical probe position: The material is allowed to cover the probe rod to the elevation where the high switch action is to occur; the set point pot is turned until the relay operates. The material level is lowered to the elevation where low switch action is to occur; the differential pot is turned until the relay reverses position. Calibration is complete.

MODEL NUMBERING SYSTEM

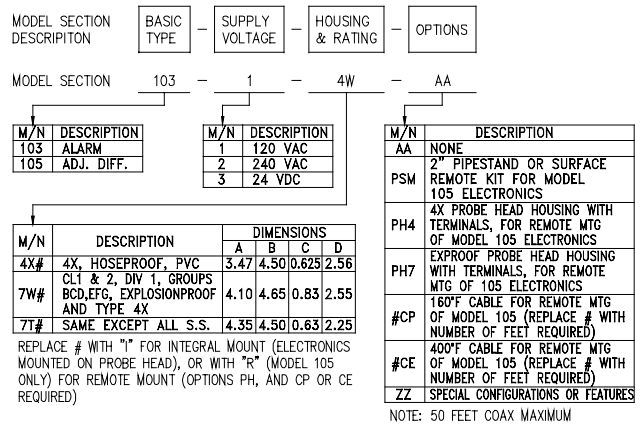

OUTLINE DIMENSIONS

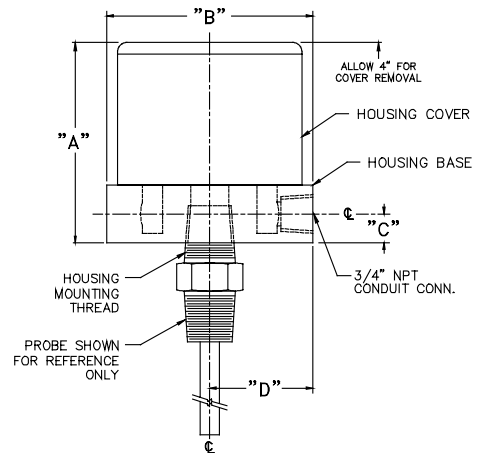

MODULE LAYOUT WITH WIRING

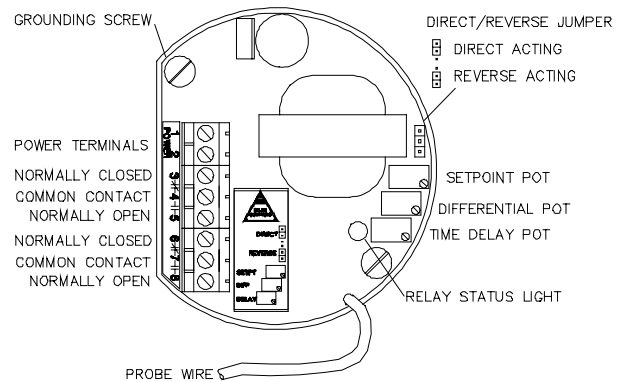

THIRD PARTY LISTINGS

**HOUSING: CSA (CANADA) NRTL/C (USA)
3A SANITARY (WORLDWIDE)
ISO 9001 QUALITY SYSTEM**

DELTA CONTROLS Corporation

585 FORTSON STREET
SHREVEPORT, LA. 71107 - USA
PHONE: 318-424-8471 FAX: 318-425-2421

e-mail: delta@deltacnt.com Web Site: <http://www.deltacnt.com>

